

R&S® ZNLE VECTOR NETWORK ANALYZER

3
year
warranty

Specifications



Data Sheet
Version 05.00

ROHDE & SCHWARZ

Make ideas real



CONTENTS

Definitions	3
Specifications.....	4
Measurement range	4
Measurement speed.....	6
Measurement accuracy	8
Effective system data.....	10
Factory-calibrated system data	10
Trace stability	10
Test port output	11
Test port input	11
Display	12
Front panel connectors	12
Rear panel connectors.....	12
Options	12
R&S®FPL1-B10	12
General data	13
Dimensions (in mm).....	14
Ordering information	15

Definitions

General

Product data applies under the following conditions:

- Three hours storage at ambient temperature followed by 30 minutes warm-up operation
- Specified environmental conditions met
- Recommended calibration interval adhered to
- All internal automatic adjustments performed, if applicable

Specifications with limits

Represent warranted product performance by means of a range of values for the specified parameter. These specifications are marked with limiting symbols such as $<$, \leq , $>$, \geq , \pm , or descriptions such as maximum, limit of, minimum. Compliance is ensured by testing or is derived from the design. Test limits are narrowed by guard bands to take into account measurement uncertainties, drift and aging, if applicable.

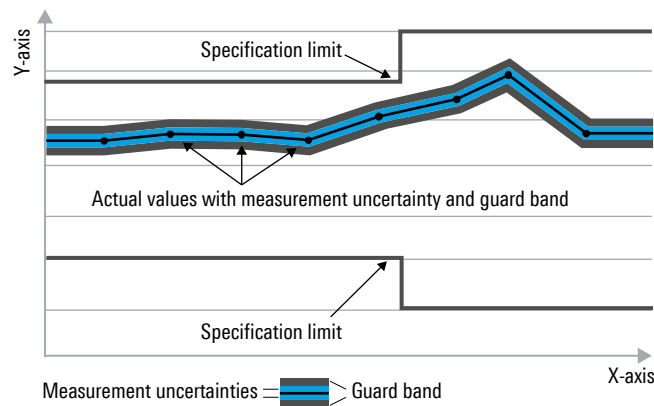

Non-traceable specifications with limits (n. trc.)

Represent product performance that is specified and tested as described under “Specifications with limits” above. However, product performance in this case cannot be warranted due to the lack of measuring equipment traceable to national metrology standards. In this case, measurements are referenced to standards used in the Rohde & Schwarz laboratories.

Specifications without limits

Represent warranted product performance for the specified parameter. These specifications are not specially marked and represent values with no or negligible deviations from the given value (e.g. dimensions or resolution of a setting parameter). Compliance is ensured by design.

Typical data (typ.)

Characterizes product performance by means of representative information for the given parameter. When marked with $<$, $>$ or as a range, it represents the performance met by approximately 80 % of the instruments at production time. Otherwise, it represents the mean value.

Nominal values (nom.)

Characterize product performance by means of a representative value for the given parameter (e.g. nominal impedance). In contrast to typical data, a statistical evaluation does not take place and the parameter is not tested during production.

Measured values (meas.)

Characterize expected product performance by means of measurement results gained from individual samples.

Uncertainties

Represent limits of measurement uncertainty for a given measurand. Uncertainty is defined with a coverage factor of 2 and has been calculated in line with the rules of the Guide to the Expression of Uncertainty in Measurement (GUM), taking into account environmental conditions, aging, wear and tear.

Device settings and GUI parameters are designated with the format “parameter: value”.

Non-traceable specifications with limits, typical data as well as nominal and measured values are not warranted by Rohde & Schwarz.

In line with the 3GPP/3GPP2 standard, chip rates are specified in million chips per second (Mcps), whereas bit rates and symbol rates are specified in billion bits per second (Gbps), million bits per second (Mbps), thousand bits per second (kbps), million symbols per second (MSPS) or thousand symbols per second (kSPS), and sample rates are specified in million samples per second (Msample/s). Gbps, Mcps, Mbps, MSPS, kbps, kSPS and Msample/s are not SI units.

Specifications

Measurement range

Impedance		50 Ω
Test port connector		N female
Number of test ports		2
Frequency range ¹	without R&S®ZNLE-B100 low frequency extension option	
	R&S®ZNLE3	1 MHz to 3 GHz
	R&S®ZNLE4	1 MHz to 4.5 GHz
	R&S®ZNLE6	1 MHz to 6 GHz
	R&S®ZNLE14	1 MHz to 14 GHz
	R&S®ZNLE18	1 MHz to 18 GHz (overrange to 20 GHz)
	with R&S®ZNLE-B100 low frequency extension option	
	R&S®ZNLE3	100 kHz to 3 GHz
	R&S®ZNLE4	100 kHz to 4.5 GHz
	R&S®ZNLE6	100 kHz to 6 GHz
	R&S®ZNLE14	100 kHz to 14 GHz
	R&S®ZNLE18	100 kHz to 18 GHz (overrange to 20 GHz)

Static frequency accuracy		(time since last adjustment \times aging rate) + temperature drift + calibration accuracy
Aging per year		$\pm 1 \times 10^{-6}$
Temperature drift (+5 °C to +40 °C)		$\pm 1 \times 10^{-6}$
Achievable initial calibration accuracy		$\pm 5 \times 10^{-7}$

Frequency resolution		1 Hz
Number of measurement points	per trace	1 to 5001
Measurement bandwidth	1/1.5/2/3/5/7 steps	1 Hz to 500 kHz

¹ Specified and typical data given in this data sheet apply to the R&S®ZNLE3, R&S®ZNLE4, R&S®ZNLE6, R&S®ZNLE14 and R&S®ZNLE18; please note their respective frequency ranges.

		specification	typical
Dynamic range ²	R&S®ZNLE3, R&S®ZNLE4 and R&S®ZNLE6		
	100 kHz to 50 MHz	> 100 dB	110 dB
	50 MHz to 6 GHz	> 110 dB	120 dB
	R&S®ZNLE14 and R&S®ZNLE18		
	100 kHz to 50 MHz	> 100 dB	110 dB
	50 MHz to 16 GHz	> 105 dB	120 dB
	16 GHz to 18 GHz	> 100 dB	110 dB
	18 GHz to 20 GHz		110 dB

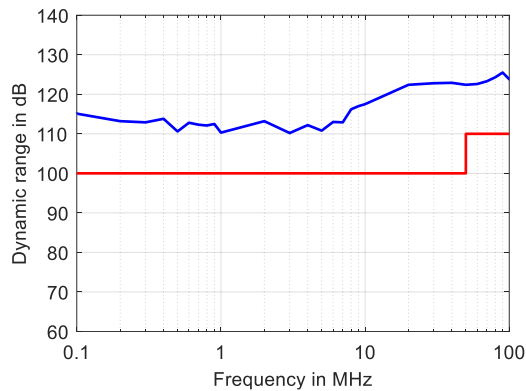

Measured dynamic range in dB versus frequency for the R&S®ZNLE3, R&S®ZNLE4 and R&S®ZNLE6

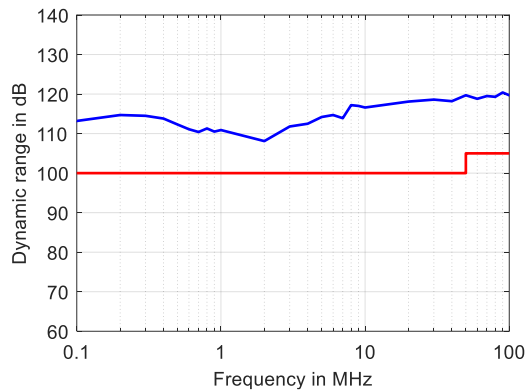
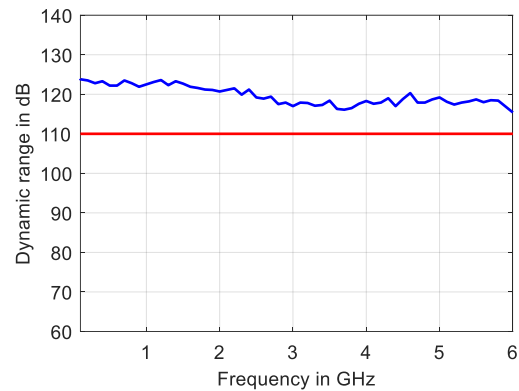

Measured dynamic range in dB versus frequency for the R&S®ZNLE14 and R&S®ZNLE18

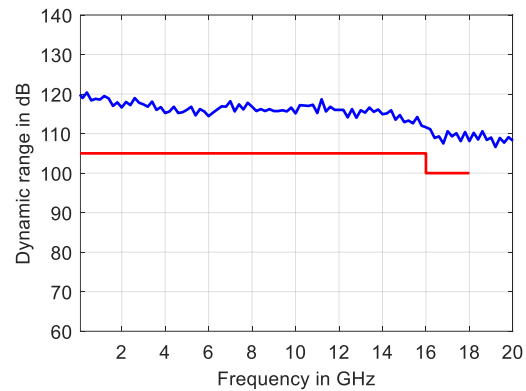

² The dynamic range is defined as the difference between 0 dBm source power and the RMS value of the data trace of the transmission magnitude, which is produced by noise and crosstalk with the test ports short-circuited. The specification applies at 10 Hz measurement bandwidth, without system error correction. The dynamic range can be increased by using a measurement bandwidth of 1 Hz.

Measurement speed

Measurement time	sweep type: CW, center frequency: 1 GHz, meas.: S11, bandwidth: selectivity normal, number of points: 201	
Time per sweep (T_{SWEEP})	bandwidth 500 kHz	920 μ s
	bandwidth 100 kHz	2.65 ms
Sweep cycle time (T_{CYCLE})	bandwidth 500 kHz	1.6 ms (meas.)
	bandwidth 100 kHz	3.6 ms (meas.)
Preparation time per sweep point (T_{PREP})	0.6 μ s ³	
Acquisition time per point (T_{ACQ})	bandwidth 500 kHz	4.0 μ s
	bandwidth 100 kHz	12.7 μ s
Total time per point (T_{POINT})	bandwidth 500 kHz	4.6 μ s
	bandwidth 100 kHz	13.2 μ s

Data transfer time	sweep type: CW, center frequency: 1 GHz, meas.: S11, bandwidth: 500 kHz Selectivity normal			
		IEC/IEEE	VXI11	HiSLIP
over 1 GBit/s LAN				
Time for measurement and data transfer (magnitude, REAL32) ⁴ , includes all necessary remote commands	for 201 measurements points	10 ms (meas.)	8 ms (meas.)	8 ms (meas.)
	for 5001 measurements points	46 ms (meas.)	31 ms (meas.)	31 ms (meas.)
Data transfer time (magnitude, REAL32), includes all necessary remote commands	for 201 measurements points	4 ms (meas.)	2.5 ms (meas.)	2.5 ms (meas.)
	for 5001 measurements points	18 ms (meas.)	3.5 ms (meas.)	3.5 ms (meas.)

Measurement sequence

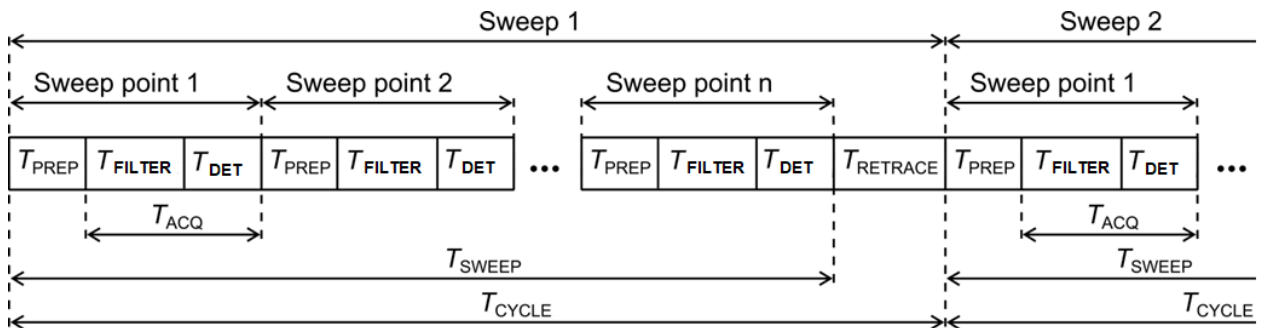

- T_{PREP} Preparation time required to set up the internal hardware components
- T_{FILTER} Filter settling time (settling time of the digital filters)
- T_{DET} Detector time (additional time for averaging of detector sample, normally 0)
- T_{ACQ} Data acquisition time ($T_{ACQ} = T_{FILTER} + T_{DET}$)
- T_{POINT} Total time for one sweep point
- T_{SWEEP} Time required for one sweep
- $T_{RETRACE}$ Time between two sweeps
- T_{CYCLE} Sweep cycle time ($T_{CYCLE} = T_{SWEEP} + T_{RETRACE}$)

³ Only sweep type "CW". When sweep type "Lin Freq" or "Log Freq" preparation time increases.

⁴ In continuous mode, no additional time for data transfer is needed, as data transfer takes place simultaneously with the measurement.

Nominal sweep times in ms versus number of measurement					
Number of measurement points	51	201	401	1601	5001
R&S®ZNLE3, R&S®ZNLE4 and R&S®ZNLE6					
800 MHz start frequency, 1 GHz stop frequency, 100 kHz measurement bandwidth					
With correction switched off	2.4	4.9	8.7	31.2	94
With 2-port TOSM calibration	3.9	9.6	16.7	61.7	189
800 MHz start frequency, 1 GHz stop frequency, 1 kHz measurement bandwidth					
With correction switched off	66	258	515	2055	6400
With 2-port TOSM calibration	132	515	1028	4100	12780
100 MHz start frequency, 3 GHz stop frequency, 100 kHz measurement bandwidth					
With correction switched off	3.9	9.1	14.5	36.7	102
With 2-port TOSM calibration	7.3	17.7	28.8	73.3	206
100 MHz start frequency, 3 GHz stop frequency, 1 kHz measurement bandwidth					
With correction switched off	68	262	519	2055	6390
With 2-port TOSM calibration	136	524	1040	4110	12800
100 MHz start frequency, 6 GHz stop frequency, 100 kHz measurement bandwidth					
With correction switched off	3.9	9.5	15.4	47	104
With 2-port TOSM calibration	7.3	18.8	30.5	95	209
100 MHz start frequency, 6 GHz stop frequency, 1 kHz measurement bandwidth					
With correction switched off	68	263	521	2070	6400
With 2-port TOSM calibration	136	525	1042	4120	12800
R&S®ZNLE14 and R&S®ZNLE18					
9 GHz start frequency, 10 GHz stop frequency, 100 kHz measurement bandwidth					
With correction switched off	5.3	11.8	18.8	59	174
With 2-port TOSM calibration	9.9	22.7	36.5	117	347
9 GHz start frequency, 10 GHz stop frequency, 1 kHz measurement bandwidth					
With correction switched off	69.4	265	524	2077	6491
With 2-port TOSM calibration	138	529	1047	4159	13524
100 MHz start frequency, 14 GHz stop frequency, 100 kHz measurement bandwidth					
With correction switched off	12.7	31.1	52.4	140	287
With 2-port TOSM calibration	24.7	61.4	104	281	577
100 MHz start frequency, 14 GHz stop frequency, 1 kHz measurement bandwidth					
With correction switched off	76.9	284	558	2160	6614
With 2-port TOSM calibration	153	568	1115	4326	13800
100 MHz start frequency, 20 GHz stop frequency, 100 kHz measurement bandwidth					
With correction switched off	12.7	31.4	51.4	134	294
With 2-port TOSM calibration	24.8	62.2	102	269	589
100 MHz start frequency, 20 GHz stop frequency, 1 kHz measurement bandwidth					
With correction switched off	76.9	285	556	2154	6622
With 2-port TOSM calibration	153	569	1113	4314	13819

Measurement accuracy

This data is valid between +18 °C and +28 °C, provided the temperature has not varied by more than 1 °C since calibration. Validity of the data is conditional on the use of an R&S®ZV-Z270 calibration kit and TOSM/SOLT calibration. This calibration kit is used to achieve the effective system data specified below. Frequency points, measurement bandwidth and sweep time have to be identical for measurement and calibration (no interpolation allowed).

Uncertainty of transmission measurements		Magnitude	Phase
100 kHz to 6 GHz	0 dB to -20 dB	0.08 dB	0.5°
	-20 dB to -30 dB	0.08 dB	0.5°
	-30 dB to -40 dB	0.08 dB	0.5°
	-40 dB to -50 dB	0.09 dB	0.6°
	-50 dB to -60 dB	0.19 dB	1.2°
6 GHz to 18 GHz	0 dB to -20 dB	0.08 dB	0.7°
	-20 dB to -30 dB	0.08 dB	0.7°
	-30 dB to -40 dB	0.09 dB	0.7°
	-40 dB to -50 dB	0.12 dB	0.9°
	-50 dB to -60 dB	0.31 dB	2.1°

Specifications are based on a matched DUT, a measurement bandwidth of 10 Hz and a nominal source power of -10 dBm.

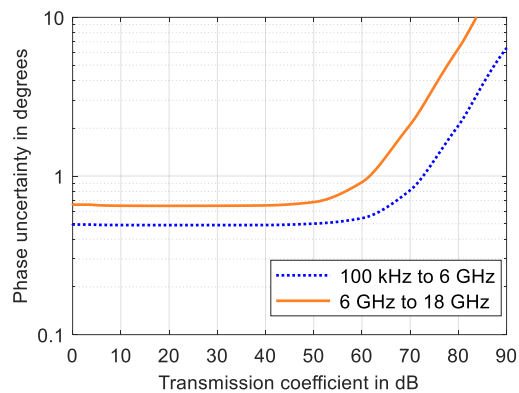
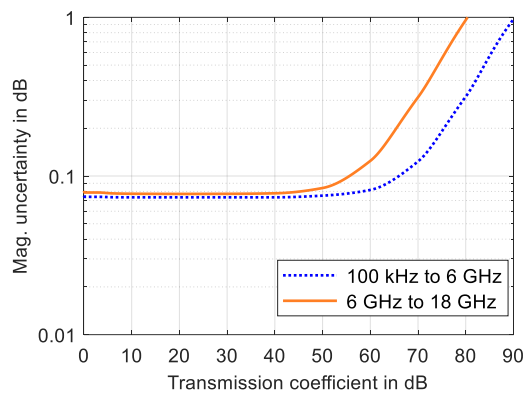

Measured uncertainty of transmission magnitude and transmission phase measurements for the R&S®ZNLE 1; analysis conditions: $S_{11} = S_{22} = 0$, calibrated power -10 dBm, measured power -10 dBm

Uncertainty of reflection measurements	Logarithmic			Linear	
	Reflection level	Magnitude	Phase	Reflection range	Magnitude
100 kHz to 10 GHz	0 dB	0.14 dB	0.9°	0 dB to -3 dB	0.016
	-3 dB	0.14 dB	0.9°	-3 dB to -6 dB	0.011
	-6 dB	0.15 dB	1.0°	-6 dB to -15 dB	0.009
	-15 dB	0.31 dB	1.9°	-15 dB to -25 dB	0.006
	-25 dB	0.89 dB	6.9°	-25 dB to -35 dB	0.006
	-35 dB	2.53 dB	34.3°	-35 dB	0.006
10 GHz to 18 GHz	0 dB	0.18 dB	1.3°	0 dB to -3 dB	0.021
	-3 dB	0.18 dB	1.3°	-3 dB to -6 dB	0.015
	-6 dB	0.20 dB	1.4°	-6 dB to -15 dB	0.012
	-15 dB	0.41 dB	2.5°	-15 dB to -25 dB	0.009
	-25 dB	1.14 dB	9.0°	-25 dB to -35 dB	0.008
	-35 dB	3.19 dB	45.0°	-35 dB	0.008

Specifications are based on an isolating DUT, a measurement bandwidth of 10 Hz and a nominal source power of -10 dBm.

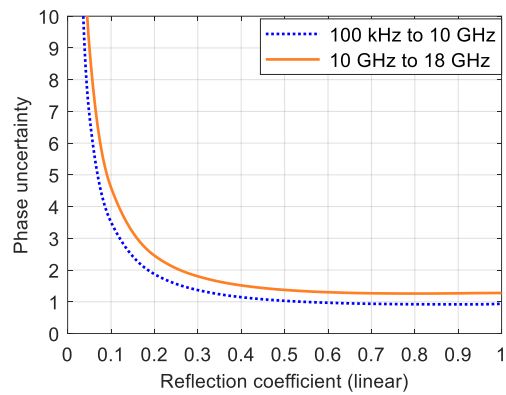
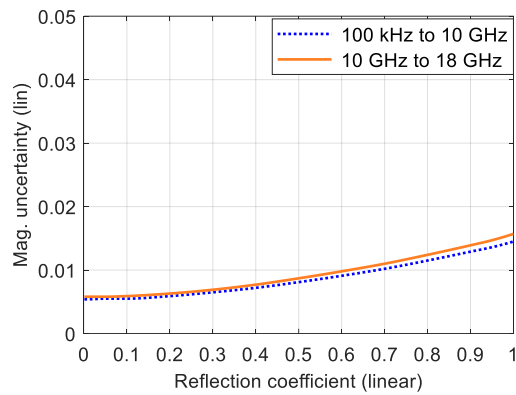

Measured uncertainty of reflection magnitude and reflection phase measurements for the R&S®ZNLE¹; analysis conditions: $S_{12} = S_{21} = 0$, calibrated power -10 dBm, measured power -10 dBm

Effective system data

This data is valid between +18 °C and +28 °C, provided the temperature has not varied by more than 1 °C since calibration. Validity of the data is conditional on the use of an R&S®ZV-Z270 calibration kit and TOSM/SOLT calibration. This calibration kit is used to achieve the effective system data specified below. Frequency points, measurement bandwidth and sweep time have to be identical for measurement and calibration (no interpolation allowed).

	100 kHz to 10 GHz	10 GHz to 18 GHz
Directivity	≥ 46 dB	≥ 42 dB
Source match	≥ 40 dB	≥ 37 dB
Load match	≥ 42 dB	≥ 38 dB
Reflection tracking	≤ 0.07 dB	≤ 0.09 dB
Transmission tracking	≤ 0.06 dB	≤ 0.06 dB

Factory-calibrated system data

This data is valid between +18 °C and +28 °C. It is based on a source power of -10 dBm and a measurement bandwidth of 1 kHz.

		specification	typical
Directivity	100 kHz to 18 GHz	≥ 20 dB	30 dB
Source match	100 kHz to 18 GHz	≥ 20 dB	30 dB
Reflection tracking	100 kHz to 6 GHz	≤ 1.5 dB	0.5 dB
	6 GHz to 18 GHz	≤ 2 dB	0.5 dB
Transmission tracking	100 kHz to 6 GHz	≤ 1.5 dB	0.5 dB
	6 GHz to 18 GHz	≤ 2 dB	0.5 dB
Load match (raw test port match)	R&S®ZNLE3, R&S®ZNLE4 and R&S®ZNLE6		
	100 kHz to 3 GHz	≥ 14 dB	18 dB
	3 GHz to 6 GHz	≥ 12 dB	16 dB
	R&S®ZNLE14 and R&S®ZNLE18		
	100 kHz to 1 GHz	≥ 17 dB	24 dB
	1 GHz to 3 GHz	≥ 13 dB	20 dB
	3 GHz to 10 GHz	≥ 10 dB	16 dB
	10 GHz to 18 GHz	≥ 7 dB	15 dB

Trace stability

		specification	typical
Trace noise magnitude (RMS) ⁵	source power 0 dBm, 0 dB reflection, bandwidth 10 kHz		
	100 kHz to 10 GHz	< 0.005 dB	0.0010 dB
	10 GHz to 18 GHz	< 0.005 dB	0.0025 dB
	18 GHz to 20 GHz		0.0025 dB
Trace noise phase (RMS) ⁵	source power 0 dBm, 0 dB reflection, bandwidth 10 kHz		
	100 kHz to 10 MHz	< 0.1°	
	10 MHz to 10 GHz	< 0.05°	0.01°
	10 GHz to 18 GHz	< 0.05°	0.02°
	18 GHz to 20 GHz		0.02°

		magnitude	phase
Measured temperature stability	source power -10 dBm, 0 dB transmission or reflection		
	R&S®ZNLE3, R&S®ZNLE4 and R&S®ZNLE6		
	100 kHz to 6 GHz	0.05 dB/K	0.8°/K
	R&S®ZNLE14 and R&S®ZNLE18		
	100 kHz to 10 GHz	0.02 dB/K	0.15°/GHz/K
	10 GHz to 20 GHz	0.03 dB/K	0.15°/GHz/K

⁵ The RMS value describes trace noise, which is produced by noise.

Test port output

This data is valid from +18 °C to +28 °C.

		specification	typical
Power range	100 kHz to 18 GHz	-10 dBm to 0 dBm	up to +2 dBm
	18 GHz to 20 GHz		up to +2 dBm
Power accuracy, source power -10 dBm	100 kHz to 18 GHz	≤ 2 dB	0.5 dB
	18 GHz to 20 GHz		0.5 dB
Power linearity, referenced to -10 dBm	100 kHz to 6 GHz	≤ 1.5 dB	0.2 dB
	6 GHz to 18 GHz	≤ 2.0 dB	0.3 dB
	18 GHz to 20 GHz		0.3 dB
Power resolution		0.01 dB	
Harmonics	source power -10 dBm		
	R&S®ZNLE3, R&S®ZNLE4 and R&S®ZNLE6		
	100 kHz to 6 GHz		-30 dBc
	R&S®ZNLE14 and R&S®ZNLE18		
	10 MHz to 9 GHz		-30 dBc

Test port input

		specification	typical
Maximum nominal input level		0 dBm	
Power measurement accuracy	at -10 dBm without power calibration		
	100 kHz to 18 GHz	< 2 dB	0.3 dB
	18 GHz to 20 GHz		0.3 dB
Receiver linearity	referenced to -10 dBm		
	+10 dB to +5 dB	< 0.3 dB	0.2 dB
	+5 dB to -40 dB	< 0.2 dB	0.1 dB
Damage level		+27 dBm	
Damage DC voltage		30 V	
Noise level ⁶	measurement bandwidth 1 kHz, normalized to 1 Hz		
	100 kHz to 50 MHz	< -110 dBm (1 Hz)	-130 dBm (1 Hz)
	50 MHz to 6 GHz	< -120 dBm (1 Hz)	-130 dBm (1 Hz)
	6 GHz to 16 GHz	< -118 dBm (1 Hz)	-125 dBm (1 Hz)
	16 GHz to 18 GHz	< -115 dBm (1 Hz)	-115 dBm (1 Hz)
	18 GHz to 20 GHz		-115 dBm (1 Hz)

⁶ The noise level is defined as the RMS value of the specified noise floor.

Display

Screen	26.4 cm (10.1") diagonal WXGA color LCD with touchscreen
Resolution	1280 × 800 × 262144 (high color, 125 dpi)
Pixel failure rate	$< 1 \times 10^{-5}$

Front panel connectors

USB	two universal serial bus connectors for connecting USB devices (USB 2.0), two additional USB 3.0 connectors on rear panel
-----	---

Rear panel connectors

LAN	local area network connector, 10/100/1000BASE-T, 8-pin, RJ-45
-----	---

USB	two universal serial bus connectors for connecting USB devices (USB 3.0), two additional USB 2.0 connectors on front panel
-----	--

MONITOR	DVI-D connector (for external monitor)
---------	--

REF IN	input for external frequency reference signal	
Connector type		BNC, female
Input frequency		10 MHz
Maximum permissible deviation		1 kHz
Input power		-10 dBm to +15 dBm at 50 Ω
Input impedance		> 10 kΩ

REF OUT	output for external frequency reference signal	
Connector type		BNC, female
Output frequency		10 MHz
Output frequency accuracy		80 Hz
Output power		+6 dBm ± 4 dB at 50 Ω

EXT TRIG IN	trigger input for analyzer	
Connector type		BNC, female
TTL signal (edge-triggered or level-triggered)		3 V, 5 V tolerant
Polarity (selectable)		positive or negative
Minimum pulse width		1 μs
Input impedance		> 10 kΩ

Options

For subsequently activated options, all data sheet parameters are typical values until a calibration is performed.

R&S® FPL1-B10

GPIB interface	remote control interface, in line with IEEE 488, IEC 60625; 24-pin
-----------------------	--

General data

Data storage		
Internal	standard	solid-state drive 32 Gbyte (nom.)
External		supports USB-2.0-compatible memory devices

Environmental conditions		
Temperature	operating temperature range	+5 °C to +40 °C
	storage temperature range	-20 °C to +70 °C
Climatic loading	without condensation	+40 °C at 85 % rel. humidity, in line with EN 60068-2-30

Mechanical resistance		
Vibration	sinusoidal	5 Hz to 55 Hz, 0.15 mm constant amplitude (1.8 g at 55 Hz), in line with EN 60068-2-6
		55 Hz to 150 Hz, acceleration: 0.5 g constant, in line with EN 60068-2-6
	random	10 Hz to 300 Hz, acceleration 1.2 g (RMS), in line with EN 60068-2-64
Shock		40 g shock spectrum, in line with MIL-STD-810E method No. 516.4 procedure I, MIL-PRF-28800F

EMC		in line with EMC Directive 2014/30/EU including IEC/EN 61326-1 ^{7, 8} , IEC/EN 61326-2-1, CISPR 11/EN 55011 ⁷ , IEC/EN 61000-3-2, IEC/EN 61000-3-3
-----	--	--

Recommended calibration interval		1 year
----------------------------------	--	--------

Power supply		
AC supply		100 V to 240 V ± 10 %, 50 Hz to 60 Hz ± 5 %, 400 Hz ± 5 % class of protection I, in line with VDE 411
Current consumption		1.7 A to 0.8 A
Power consumption		max. 170 W, 80 W (typ.)
Safety		in line with EN 61010-1, IEC 61010-1, UL 61010-1, CAN/CSA-C22.2 No. 61010-1
Test mark		CE, cCSA _{US} , KCC

Dimensions and weight		
Dimensions	W × H × D	408 mm × 186 mm × 235 mm (16.06 in × 7.32 in × 9.25 in)
Net weight, nominal		6 kg (13.22 lb)

⁷ Emission limits for class A equipment.

⁸ Immunity test requirement for industrial environment (EN 61326 table 2).

Dimensions (in mm)

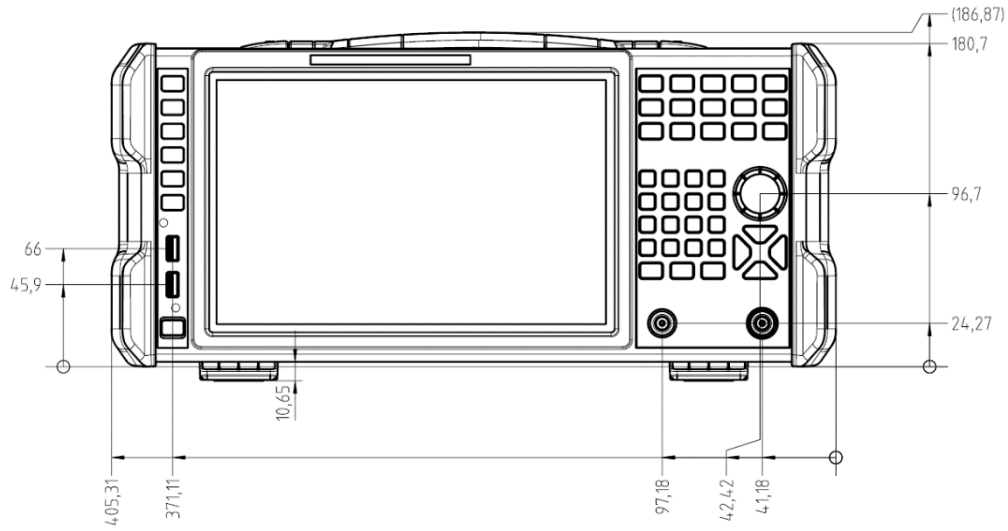

Front view

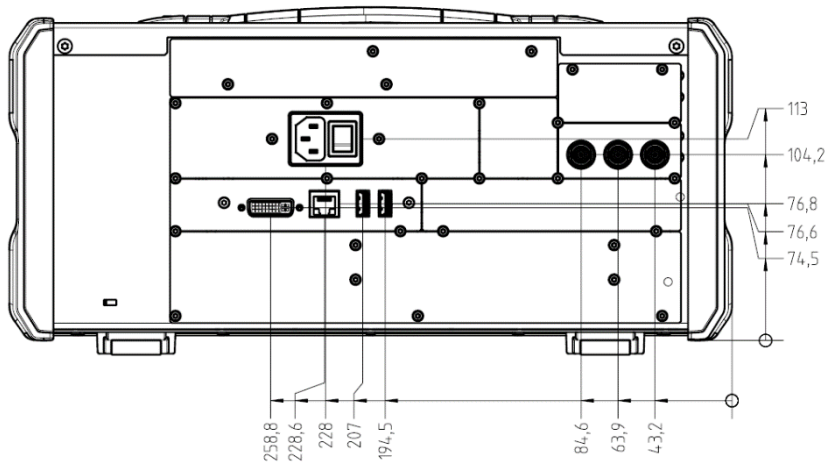

Rear view

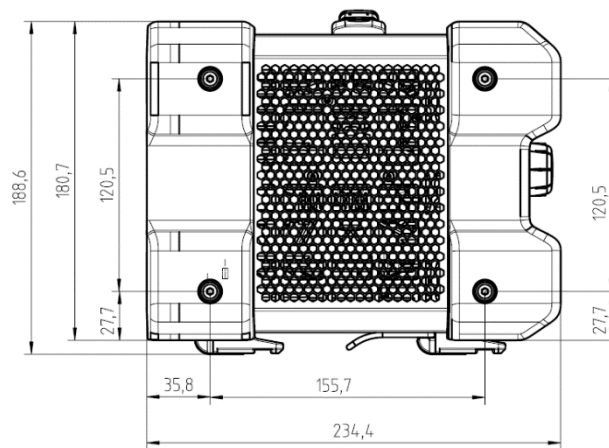

Side view

Ordering information

Designation	Type	Retrofit ⁹	On site ¹⁰	Order No.
Base unit				
Vector network analyzer, 3 GHz, N connectors	R&S [®] ZNLE3			1323.0012K53
Vector network analyzer, 4.5 GHz, N connectors	R&S [®] ZNLE4			1323.0012K54
Vector network analyzer, 6 GHz, N connectors	R&S [®] ZNLE6			1323.0012K56
Vector network analyzer, 14 GHz, N connectors	R&S [®] ZNLE14			1323.0012K64
Vector network analyzer, 18 GHz (20 GHz), N connectors	R&S [®] ZNLE18			1323.0012K70
Options				
Low frequency extension	R&S [®] ZNLE-B100	•	–	1303.9272.02
GPIB interface	R&S [®] FPL1-B10	•	•	1323.1890.02
Firmware/software				
Time domain analysis	R&S [®] ZNL-K2	•	•	1323.1819.02
Distance-to-fault measurement	R&S [®] ZNL-K3	•	•	1323.1825.02

Warranty				
Base unit				3 years
All other items ¹¹				1 year
Options				
Extended warranty, one year	R&S [®] WE1			Please contact your local Rohde & Schwarz sales office.
Extended warranty, two years	R&S [®] WE2			
Extended warranty with calibration coverage, one year	R&S [®] CW1			
Extended warranty with calibration coverage, two years	R&S [®] CW2			
Extended warranty with accredited calibration coverage, one year	R&S [®] AW1			
Extended warranty with accredited calibration coverage, two years	R&S [®] AW2			

Extended warranty with a term of one and two years (WE1 and WE2)

Repairs carried out during the contract term are free of charge ¹². Necessary calibration and adjustments carried out during repairs are also covered.

Extended warranty with calibration coverage (CW1 and CW2)

Enhance your extended warranty by adding calibration coverage at a package price. This package ensures that your Rohde & Schwarz product is regularly calibrated, inspected and maintained during the term of the contract. It includes all repairs ¹² and calibration at the recommended intervals as well as any calibration carried out during repairs or option upgrades.

Extended warranty with accredited calibration (AW1 and AW2)

Enhance your extended warranty by adding accredited calibration coverage at a package price. This package ensures that your Rohde & Schwarz product is regularly calibrated under accreditation, inspected and maintained during the term of the contract. It includes all repairs ¹² and accredited calibration at the recommended intervals as well as any accredited calibration carried out during repairs or option upgrades.

⁹ Option may also be ordered at a later stage, upgrade in service.

¹⁰ Option may be installed by the user on site.

¹¹ For options that are installed, the remaining base unit warranty applies if longer than 1 year.

¹² Excluding defects caused by incorrect operation or handling and force majeure. Wear-and-tear parts are not included.

Service that adds value

- ▶ Worldwide
- ▶ Local and personalized
- ▶ Customized and flexible
- ▶ Uncompromising quality
- ▶ Long-term dependability

Rohde & Schwarz

The Rohde&Schwarz technology group is among the trail-blazers when it comes to paving the way for a safer and connected world with its leading solutions in test & measurement, technology systems, and networks & cybersecurity. Founded more than 85 years ago, the group is a reliable partner for industry and government customers around the globe. The independent company is headquartered in Munich, Germany and has an extensive sales and service network with locations in more than 70 countries.

www.rohde-schwarz.com

Sustainable product design

- ▶ Environmental compatibility and eco-footprint
- ▶ Energy efficiency and low emissions
- ▶ Longevity and optimized total cost of ownership

Certified Quality Management
ISO 9001

Certified Environmental Management
ISO 14001

DISTRAME

Parc du Grand Troyes - Quartier Europe Centrale, 40 rue de Vienne - 10300 SAINTE-SAVINE
Tél. : 03 25 71 25 83 - infos@distrame.fr - www.distrame.fr