

# 2182A

# Nanovoltmeter



The two-channel Model 2182A Nanovoltmeter is optimized for making stable, low noise voltage measurements and for characterizing low resistance materials and devices reliably and repeatably. It provides higher measurement speed and significantly better noise performance than alternative low voltage measurement solutions.

The Model 2182A represents the next step forward in Keithley nanovoltmeter technology, replacing the original Model 2182 and offering enhanced capabilities including pulse capability, lower measurement noise, faster current reversals, and a simplified delta mode for making resistance measurements in combination with a reversing current source, such as the Model 6220 or 6221.

- Make low noise measurements at high speeds, typically just 15nV p-p noise at 1s response time, 40–50nV p-p noise at 60ms
- Delta mode coordinates measurements with a reversing current source at up to 24Hz with 30nV p-p noise (typical) for one reading. Averages multiple readings for greater noise reduction
- Synchronization to line provides 110dB NMRR and minimizes the effect of AC common-mode currents
- Dual channels support measuring voltage, temperature, or the ratio of an unknown resistance to a reference resistor
- Built-in thermocouple linearization and cold junction compensation

## Flexible, Effective Speed/Noise Trade-offs

The Model 2182A makes it easy to choose the best speed/filter combination for a particular application's response time and noise level requirements. The ability to select from a wide range of response times allows optimizing speed/noise trade-offs. Low noise levels are assured over a wide range of useful response times, e.g., 15nV p-p noise at 1s and 40-50nV p-p noise at 60ms are typical. **Figure 1** illustrates the Model 2182A's noise performance.

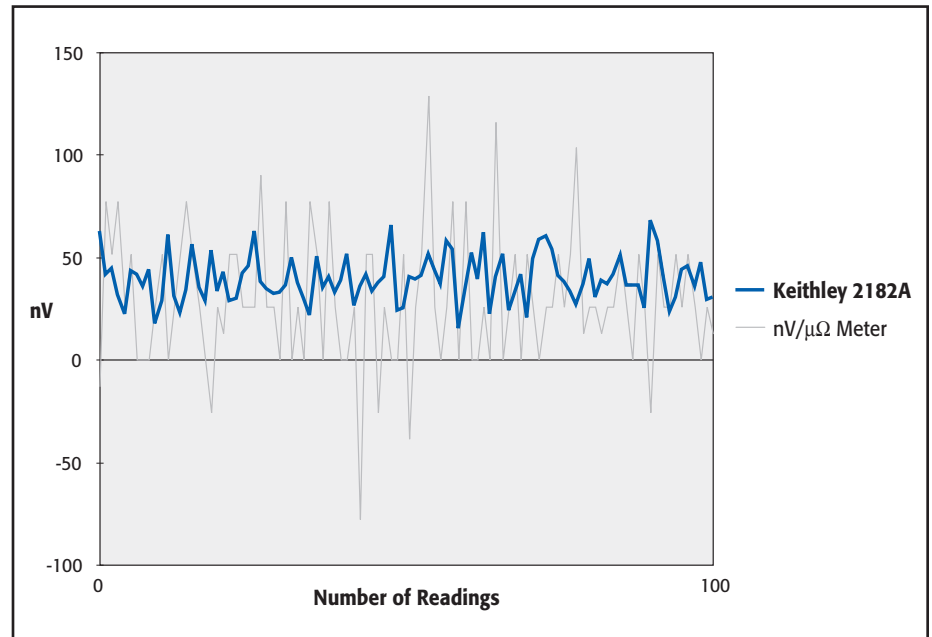

**Figure 1.** Compare the Model 2182A's DC noise performance with a nanovolt/micro-ohm-meter's. All the data shown was taken at 10 readings per second with a low thermal short applied to the input.

1.888.KEITHLEY (U.S. only)

KEITHLEY

Low noise measurements for research, metrology, and other low voltage testing applications

LOW LEVEL MEASURE & SOURCE

# 2182A

## Ordering Information

**2182A Nanovoltmeter**

### Accessories Supplied

**2107-4 Low Thermal Input Cable with spade lugs, 1.2m (4 ft).**

**User manual, service manual, contact cleaner, line cord, alligator clips.**

### ACCESSORIES AVAILABLE

2107-30	Low Thermal Input Cable with spade lugs, 9.1m (30 ft)
2182-KIT	Low Thermal Connector with strain relief
2187-4	Input Cable with safety banana plugs
2188	Low Thermal Calibration Shorting Plug
4288-1	Single Fixed Rack Mount Kit
4288-2	Dual Fixed Rack Mount Kit
7007-1	Shielded GPIB Cable, 1m (3.2 ft)
7007-2	Shielded GPIB Cable, 2m (6.5 ft)
7009-5	Shielded RS-232 Cable, 1.5m (5 ft)
8501-1	Trigger Link Cable, 1m (3.2 ft)
8501-2	Trigger Link Cable, 2m (6.5 ft)
8502	Trigger Link Adapter to 6 female BNC connectors
8503	Trigger Link Cable to 2 male BNC connectors
KPCI-488LP	IEEE-488 Interface/Controller for the PCI Bus
KPXI-488	IEEE-488 Interface Board for the PXI Bus
KUSB-488A	IEEE-488 USB-to-GPIB Interface Adapter

### SERVICES AVAILABLE

2182A-3Y-EW	1-year factory warranty extended to 3 years from date of shipment
C/2182A-3Y-ISO	3 (ISO-17025 accredited) calibrations within 3 years of purchase*
TRN-LLM-1-C	Course: Making Accurate Low-Level Measurements

\* Not available in all countries

### APPLICATIONS

#### Research

- Determining the transition temperature of superconductive materials
- I-V characterization of a material at a specific temperature
- Calorimetry

#### Metrology

- Intercomparisons of standard cells
- Null meter for resistance bridge measurements

**1.888.KEITHLEY** (U.S. only)

# Nanovoltmeter

## Reliable Results

Power line noise can compromise measurement accuracy significantly at the nanovolt level. The Model 2182A reduces this interference by synchronizing its measurement cycle to line, which minimizes variations due to readings that begin at different phases of the line cycle. The result is exceptionally high immunity to line interference with little or no shielding and filtering required.

## Optimized for Use with Model 6220/6221 Current Sources

Device test and characterization for today's very small and power-efficient electronics requires sourcing low current levels, which demands the use of a precision, low current source. Lower stimulus currents produce lower—and harder to measure—voltages across the devices. Linking the Model 2182A Nanovoltmeter with a Model 6220 or 6221 Current Source makes it possible to address both of these challenges in one easy-to-use configuration.

When connected, the Model 2182A and Model 6220 or 6221 can be operated like a single instrument. Their simple connections eliminate the isolation and noise current problems that plague other solutions. The Model 2182A/622X combination allows making delta mode and differential conductance measurements faster and with less noise than the original Model 2182 design allowed. The Model 2182A will also work together with the Model 6221 to make pulse-mode measurements.

The 2182A/622X combination is ideal for a variety of applications, including resistance measurements, pulsed I-V measurements, and differential conductance measurements, providing significant advantages over earlier solutions like lock-in amplifiers or AC resistance bridges. The 2182A/622X combination is also well suited for many nanotechnology applications because it can measure resistance without dissipating much power into the device under test (DUT), which would otherwise invalidate results or even destroy the DUT.

## An Easy-to-Use Delta Mode

Keithley originally created the delta mode method for measuring voltage and resistance for the Model 2182 and a triggerable external current source, such as the Model 2400 SourceMeter instrument. Basically, the delta mode automatically triggers the current source to alternate the signal polarity, and then triggers a nanovoltmeter reading at each polarity. This current reversal technique cancels out

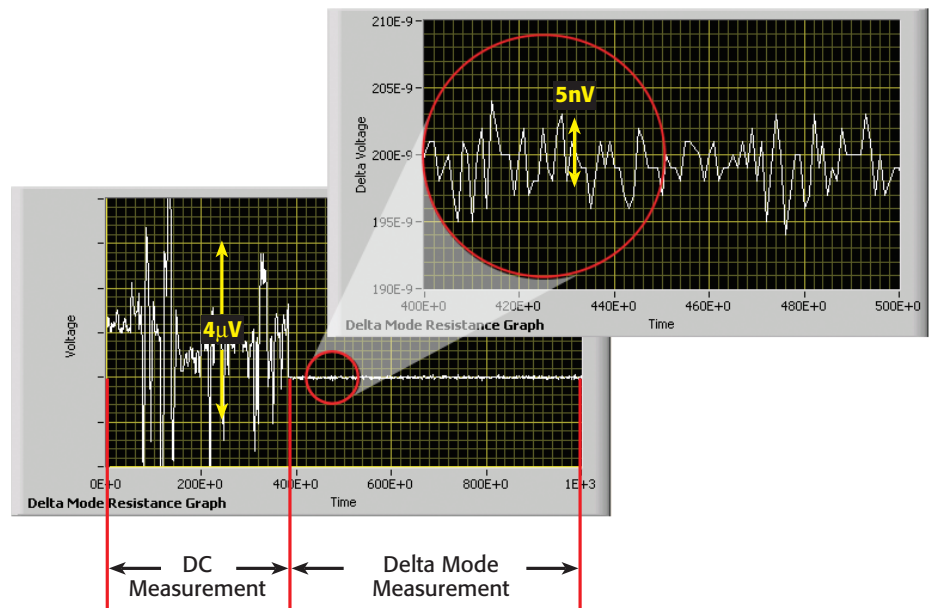

**Figure 2. Results from a Model 2182A/6220 using the delta mode to measure a 10mΩ resistor with a 20µA test current. The free Model 6220/6221 instrument control example start-up software used here can be downloaded from [www.keithley.com](http://www.keithley.com).**

# 2182A

# Nanovoltmeter

any constant thermoelectric offsets, so the results reflect the true value of the voltage being measured. The improved delta mode for the Model 2182A and the Model 622X current sources uses the same basic technique, but the way in which it's implemented has been simplified dramatically. The new technique can cancel thermoelectric offsets that drift over time (not just static offsets), produces results in half the time of the original technique, and allows the current source to control and configure the Model 2182A. Two key presses are all that's required to set up the measurement. The improved cancellation and higher reading rates reduce measurement noise to as little as 1nV.

## Differential Conductance Measurements

Characterizing non-linear tunneling devices and low temperature devices often requires measuring differential conductance (the derivative of a device's I-V curve). When used with a Model 622X current source, the Model 2182A is the industry's fastest, most complete solution for differential conductance measurements, providing 10X the speed and significantly lower noise than other instrumentation options. There's no need to average the results of multiple sweeps, because data can be obtained in a single measurement pass, reducing test time and minimizing the potential for measurement error.

## Pulsed Testing with the Model 6221

When measuring small devices, introducing even tiny amounts of heat to the DUT can raise its temperature, skewing test results or even destroying the device. When used with the Model 2182A, the Model 6221's pulse capability minimizes the amount of power dissipated into a DUT. The Model 2182A/6221 combination synchronizes the pulse and measurement. A measurement can begin as soon as  $16\mu\text{s}$  after the Model 6221 applies the pulse. The entire pulse, including a complete nanovolt measurement, can be as short as  $50\mu\text{s}$ .

In the delta, differential conductance, and pulse modes, The Model 2182A produces virtually no transient currents, so it's ideal for characterizing devices that can be easily disrupted by current spikes (see Figure 4).

## Metrology Applications

The Model 2182A combines the accuracy of a digital multimeter with low noise at high speeds for high-precision metrology applications. Its low noise, high signal observation time, fast measurement rates, and 2ppm accuracy provide the most cost-effective meter available today for applications such as intercomparison of voltage standards and direct measurements of resistance standards.

## Nanotechnology Applications

The Model 2182A combined with the Model 622X current source or Series 2400 SourceMeter<sup>®</sup> instrument is a highly accurate and repeatable solution for measuring resistances on carbon nanotube based materials and silicon nanowires.

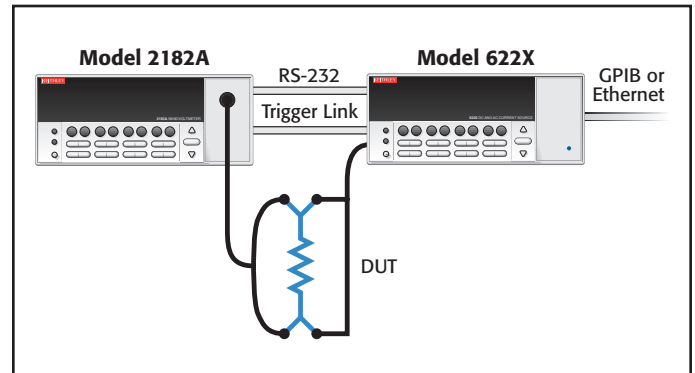

Figure 3. It's simple to connect the Model 2182A to the Model 6220 or 6221 to make a variety of measurements. The instrument control example start-up software available for the Model 622X current sources includes a step-by-step guide to setting up the instrumentation and making proper connections.

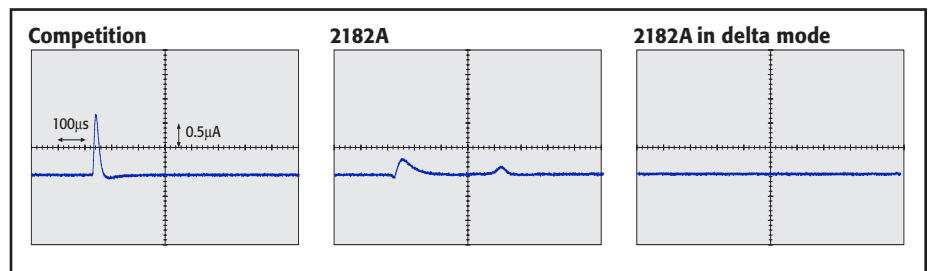

Figure 4. The Model 2182A produces the lowest transient currents of any nanovoltmeter available.

## Research Applications

The Model 2182A's 1nV sensitivity, thermoelectric EMF cancellation, direct display of "true" voltage, ability to perform calculations, and high measurement speed makes it ideal for determining the characteristics of materials such as metals, low resistance filled plastics, and high and low temperature superconductors.

Low noise measurements for research, metrology, and other low voltage testing applications

LOW LEVEL MEASURE & SOURCE

1.888.KEITHLEY (U.S. only)

KEITHLEY

## 2182A

## Nanovoltmeter

## Three Ways to Measure Nanovolts

**DC nanovoltmeters.** DC nanovoltmeters and sensitive DMMs both provide low noise DC voltage measurements by using long integration times and highly filtered readings to minimize the bandwidth near DC. Unfortunately, this approach has limitations, particularly the fact that thermal voltages develop in the sample and connections vary, so long integration times don't improve measurement precision. With a noise specification of just 6nV p-p, the Model 2182A is the lowest noise digital nanovoltmeter available, with the exception of the Keithley Model 2001 DMM/1801 Nanovolt Preamp combination, which has 0.6nV p-p noise.

**AC technique.** The limitations of the long integration and filtered readings technique have led many people to use an AC technique for measuring low resistances and voltages. In this method, an AC excitation is applied to the sample and the voltage is detected synchronously at the same frequency and an optimum phase. While this technique removes the varying DC component, in many experiments at high frequencies, users can experience problems related to phase shifts caused by spurious capacitance or the L/R time constant. At low frequencies, as the AC frequency is reduced to minimize phase shifts, amplifier noise increases.

**The current reversal method.** The Model 2182A is optimized for the current reversal method, which combines the advantages of both earlier approaches. In this technique, the DC test current is reversed, then the difference in voltage due to the difference in current is determined. Typically, this measurement is performed at a few hertz (a frequency just high enough for the current to be reversed before the thermal voltages can change). The Model 2182A's low noise performance at measurement times of a few hundred milliseconds to a few seconds means that the reversal period can be set quite small in comparison with the thermal time constant of the sample and the connections, effectively reducing the impact of thermal voltages.

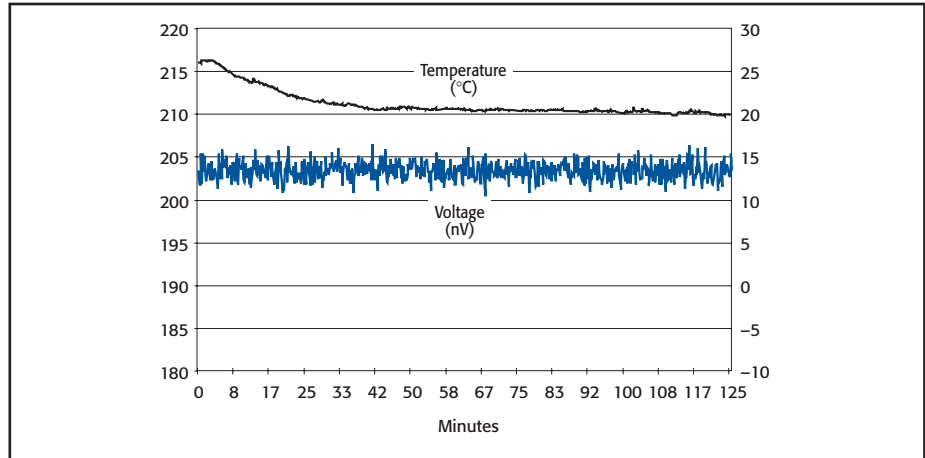

**Figure 5. The Model 2182A's delta mode provides extremely stable results, even in the presence of large ambient temperature changes. In this challenging example, the 200nV signal results from a 20 $\mu$ A current sourced by a model 6221 through a 10m $\Omega$  test resistor.**

## Optional Accessory: Model 2187-4 Test Lead Kit

The standard cabling provided with the Model 2182A Nanovoltmeter and Model 622X Current Sources provides everything normally needed to connect the instruments to each other and to the DUT. The Model 2187-4 Test Lead Kit is required when the cabling provided may not be sufficient for specific applications, such as when the DUT has special connection requirements. The kit includes an input cable with banana terminations, banana extensions, sprung-hook clips, alligator clips, needle probes, and spade lugs to accommodate virtually any DUT. The Model 2187-4 is also helpful when the DUT has roughly 1G $\Omega$  impedance or higher. In these cases, measuring with the Model 2182A directly across the DUT will lead to loading errors. The Model 2187-4 Test Lead Kit provides a banana cable and banana jack extender to allow the Model 2182A to connect easily to the Model 622X's low impedance guard output, so the Model 2182A can measure the DUT voltage indirectly. This same configuration also removes the Model 2182A's input capacitance from the DUT, so it improves device response time, which may be critical for pulsed measurements.

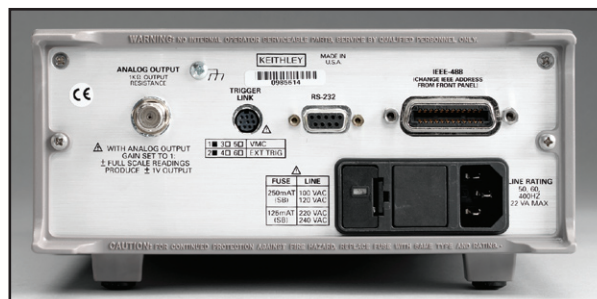

**Model 2182A rear panel**

**1.888.KEITHLEY** (U.S. only)

**KEITHLEY**

## Volts Specifications (20% over range)

CONDITIONS: 1PLC with 10 reading digital filter or 5PLC with 2 reading digital filter.

Channel 1 Range	Resolution	Input Resistance	Accuracy: ±(ppm of reading + ppm of range) (ppm = parts per million) (e.g., 10ppm = 0.001%)				Temperature Coefficient 0°–18°C & 28°–50°C
			24 Hour <sup>1</sup> T <sub>CAL</sub> ±1°C	90 Day T <sub>CAL</sub> ±5°C	1 Year T <sub>CAL</sub> ±5°C	2 Year T <sub>CAL</sub> ±5°C	
10.000000 mV <sup>2,3,4</sup>	1 nV	>10 GΩ	20 + 4	40 + 4	50 + 4	60 + 4	(1 + 0.5)/°C
100.00000 mV	10 nV	>10 GΩ	10 + 3	25 + 3	30 + 4	40 + 5	(1 + 0.2)/°C
1.0000000 V	100 nV	>10 GΩ	7 + 2	18 + 2	25 + 2	32 + 3	(1 + 0.1)/°C
10.000000 V	1 μV	>10 GΩ	2 + 1 <sup>5</sup>	18 + 2	25 + 2	32 + 3	(1 + 0.1)/°C
100.00000 V <sup>4</sup>	10 μV	10 MΩ ±1%	10 + 3	25 + 3	35 + 4	52 + 5	(1 + 0.5)/°C

Channel 2 <sup>6,10</sup>							
Range	Resolution	Input Resistance	24 Hour <sup>1</sup> T <sub>CAL</sub> ±1°C	90 Day T <sub>CAL</sub> ±5°C	1 Year T <sub>CAL</sub> ±5°C	2 Year T <sub>CAL</sub> ±5°C	Temperature Coefficient 0°–18°C & 28°–50°C
100.00000 mV	10 nV	>10 GΩ	10 + 6	25 + 6	30 + 7	40 + 7	(1 + 1 )/°C
1.0000000 V	100 nV	>10 GΩ	7 + 2	18 + 2	25 + 2	32 + 3	(1 + 0.5)/°C
10.000000 V	1 μV	>10 GΩ	2 + 1 <sup>5</sup>	18 + 2	25 + 2	32 + 3	(1 + 0.5)/°C

CHANNEL 1/CHANNEL 2 RATIO: Ratio accuracy =  $\frac{(\text{channel 2 reading (accuracy channel 1 range)} + \text{channel 1 reading (accuracy channel 2 range)})}{(\text{channel 2 reading})^2}$

DELTA (hardware-triggered coordination with Series 24XX or Series 622X current sources for low noise R measurement):

Accuracy = accuracy of selected Channel 1 range plus accuracy of I source range.

DELTA MEASUREMENT NOISE WITH 6220 or 6221: Typical  $3nV_{rms}/\sqrt{Hz}$  (10mV range)<sup>21</sup>. 1Hz achieved with 1PLC, delay = 1ms, RPT filter = 23 (20 if 50Hz).

PULSE-MODE (with 6221): Line synchronized voltage measurements within current pulses from 50μs to 12ms, pulse repetition rate up to 12Hz.

PULSE MEASUREMENT NOISE (typical rms noise, R<sub>DUT</sub> < 10Ω):  $\pm(0.009\text{ppm of range}^*) / \text{meas\_time} / \sqrt{\text{pulse\_avg\_count} + 3nV^{**} / \sqrt{2 \cdot \text{meas\_time} \cdot \text{pulse\_avg\_count}}}$  for 10mV range.

\* 0.0028ppm for the 100mV range, 0.0016ppm for ranges 1V and above.

\*\*  $8nV/\sqrt{Hz}$  for ranges above 10mV. meas\_time (seconds) = pulsewidth – pulse\_meas\_delay in 33μs inc.

## DC Noise Performance<sup>7</sup> (DC noise expressed in volts peak-to-peak)

Response time = time required for reading to be settled within noise levels from a stepped input, 60Hz operation.

### Channel 1

Response Time	NPLC, Filter	10 mV	100 mV	Range 1 V	10 V	100 V	NMRR <sup>8</sup>	CMRR <sup>9</sup>
25.0 s	5, 75	6 nV	20 nV	75 nV	750 nV	75 μV	110 dB	140 dB
4.0 s	5, 10	15 nV	50 nV	150 nV	1.5 μV	75 μV	100 dB	140 dB
1.0 s	1, 18	25 nV	175 nV	600 nV	2.5 μV	100 μV	95 dB	140 dB
667 ms	1, 10 or 5, 2	35 nV	250 nV	650 nV	3.3 μV	150 μV	90 dB	140 dB
60 ms	1, Off	70 nV	300 nV	700 nV	6.6 μV	300 μV	60 dB	140 dB

### Channel 2<sup>6,10</sup>

25.0 s	5, 75	—	150 nV	200 nV	750 nV	—	110 dB	140 dB
4.0 s	5, 10	—	150 nV	200 nV	1.5 μV	—	100 dB	140 dB
1.0 s	1, 10 or 5, 2	—	175 nV	400 nV	2.5 μV	—	90 dB	140 dB
85 ms	1, Off	—	425 nV	1 μV	9.5 μV	—	60 dB	140 dB

## VOLTAGE NOISE VS. SOURCE RESISTANCE<sup>11</sup>

(DC noise expressed in volts peak-to-peak)

Source Resistance	Noise	Analog Filter	Digital Filter
0 Ω	6 nV	Off	100
100 Ω	8 nV	Off	100
1 kΩ	15 nV	Off	100
10 kΩ	35 nV	Off	100
100 kΩ	100 nV	On	100
1 MΩ	350 nV	On	100

## TEMPERATURE (Thermocouples)<sup>12</sup>

(Displayed in °C, °F, or K. Accuracy based on ITS-90, exclusive of thermocouple errors.)

TYPE	RANGE	RESOLUTION	ACCURACY 90 Day/1 Year 23° ±5°C Relative to Simulated Reference Junction
J	–200 to +760°C	0.001 °C	±0.2 °C
K	–200 to +1372°C	0.001 °C	±0.2 °C
N	–200 to +1300°C	0.001 °C	±0.2 °C
T	–200 to +400°C	0.001 °C	±0.2 °C
E	–200 to +1000°C	0.001 °C	±0.2 °C
R	0 to +1768°C	0.1 °C	±0.2 °C
S	0 to +1768°C	0.1 °C	±0.2 °C
B	+350 to +1820°C	0.1 °C	±0.2 °C

## Operating Characteristics<sup>13, 14</sup>

### 60Hz (50Hz) Operation

Function	Digits	Readings/s	PLCs
DCV Channel 1,	7.5	3 (2)	5
Channel 2,	7.5 <sup>17, 19</sup>	6 (4)	5
Thermocouple	6.5 <sup>18, 19</sup>	18 (15)	1
	6.5 <sup>18, 19, 20</sup>	45 (36)	1
	5.5 <sup>17, 19</sup>	80 (72)	0.1
	4.5 <sup>16, 17, 19</sup>	115 (105)	0.01
Channel 1/Channel 2 (Ratio),	7.5	1.5 (1.3)	5
Delta with 24XX, Scan	7.5 <sup>17, 19</sup>	2.3 (2.1)	5
	6.5 <sup>18</sup>	8.5 (7.5)	1
	6.5 <sup>18, 20</sup>	20 (16)	1
	5.5 <sup>17</sup>	30 (29)	0.1
	4.5 <sup>17</sup>	41 (40)	0.01
Delta with 622X	6.5	47 (40.0) <sup>22</sup>	1

## System Speeds<sup>13, 15</sup>

RANGE CHANGE TIME: <sup>14</sup>	<40 ms (<50 ms).
FUNCTION CHANGE TIME: <sup>14</sup>	<45 ms (<55 ms).
AUTORANGE TIME: <sup>14</sup>	<60 ms (<70 ms).
ASCII READING TO RS-232 (19.2K Baud):	40/s (40/s).
MAX. INTERNAL TRIGGER RATE: <sup>16</sup>	120/s (120/s).
MAX. EXTERNAL TRIGGER RATE: <sup>16</sup>	120/s (120/s).

## Measurement Characteristics

A/D LINEARITY:  $\pm(0.8\text{ppm of reading} + 0.5\text{ppm of range})$ .

### FRONT AUTOZERO OFF ERROR

10mV–10V: Add  $\pm(8\text{ppm of range} + 500\mu\text{V})$  for <10 minutes and  $\pm 1^\circ\text{C}$ .

NOTE: Offset voltage error does not apply for Delta Mode.

### AUTOZERO OFF ERROR

10mV: Add  $\pm(8\text{ppm of range} + 100\text{nV})$  for <10 minutes and  $\pm 1^\circ\text{C}$ .

100mV–100V: Add  $\pm(8\text{ppm of range} + 10\mu\text{V})$  for <10 minutes and  $\pm 1^\circ\text{C}$ .

NOTE: Offset voltage error does not apply for Delta Mode.

### INPUT IMPEDANCE

10mV–10V:  $>10\text{G}\Omega$ , in parallel with  $<1.5\text{nF}$  (Front Filter ON).

10mV–10V:  $>10\text{G}\Omega$ , in parallel with  $<0.5\text{nF}$  (Front Filter OFF).

100V:  $10\text{M}\Omega \pm 1\%$ .

DC INPUT BIAS CURRENT:  $<60\text{pA DC}$  at  $23^\circ\text{C}$ ,  $-10\text{V}$  to  $5\text{V}$ .  $<120\text{pA}$  @  $23^\circ\text{C}$ ,  $5\text{V}$  to  $10\text{V}$ .

COMMON MODE CURRENT:  $<50\text{nA p-p}$  at  $50\text{Hz}$  or  $60\text{Hz}$ .

INPUT PROTECTION:  $150\text{V}$  peak to any terminal.  $70\text{V}$  peak Channel 1 LO to Channel 2 LO.

CHANNEL ISOLATION:  $>10\text{G}\Omega$ .

EARTH ISOLATION:  $350\text{V}$  peak,  $>10\text{G}\Omega$  and  $<150\text{pF}$  any terminal to earth. Add  $35\text{pF/ft}$  with Model 2107 Low Thermal Input Cable.

## Analog Output

MAXIMUM OUTPUT:  $\pm 1.2\text{V}$ .

ACCURACY:  $\pm(0.1\%$  of output +  $1\text{mV})$ .

OUTPUT RESISTANCE:  $1\text{k}\Omega \pm 5\%$ .

GAIN: Adjustable from  $10^{-9}$  to  $10^6$ . With gain set to 1, a full range input will produce a 1V output.

OUTPUT REL: Selects the value of input that represents 0V at output. The reference value can be either programmed value or the value of the previous input.

## Triggering and Memory

WINDOW FILTER SENSITIVITY: 0.01%, 0.1%, 1%, 10%, or full scale of range (none).

READING HOLD SENSITIVITY: 0.01%, 0.1%, 1%, or 10% of reading.

TRIGGER DELAY: 0 to 99 hours (1ms step size).

EXTERNAL TRIGGER DELAY:  $2\text{ms} + <1\text{ms}$  jitter with auto zero off, trigger delay = 0.

MEMORY SIZE: 1024 readings.

## Math Functions

Rel, Min/Max/Average/Std Dev/Peak-to-Peak (of stored reading), Limit Test, %, and  $mX+b$  with user-defined units displayed.

## Remote Interface

Keithley 182 emulation.

GPIB (IEEE-488.2) and RS-232C.

SCPI (Standard Commands for Programmable Instruments).

## GENERAL

POWER SUPPLY: 100V/120V/220V/240V.

LINE FREQUENCY: 50Hz, 60Hz, and 400Hz, automatically sensed at power-up.

POWER CONSUMPTION: 22VA.

MAGNETIC FIELD DENSITY: 10mV range 4.0s response noise tested to 500 gauss.

OPERATING ENVIRONMENT: Specified for  $0^\circ$  to  $50^\circ\text{C}$ . Specified to 80% RH at  $35^\circ\text{C}$ .

STORAGE ENVIRONMENT:  $-40^\circ$  to  $70^\circ\text{C}$ .

EMC: Complies with European Union Directive 89/336/EEC (CE marking requirement), FCC part 15 class B, CISPR 11, IEC 801-2, IEC-801-3, IEC 801-4.

SAFETY: Complies with European Union Directive 73/23/EEC (low voltage directive); meets EN61010-1 safety standard. Installation category I.

VIBRATION: MIL-T-28800E Type III, Class 5.

WARM-UP: 2.5 hours to rated accuracy.

DIMENSIONS: **Rack Mounting:** 89mm high  $\times$  213mm wide  $\times$  370mm deep (3.5 in  $\times$  8.375 in  $\times$  14.563 in). **Bench Configuration (with handles and feet):** 104mm high  $\times$  238mm wide  $\times$  370mm deep (4.125 in  $\times$  9.375 in  $\times$  14.563 in).

SHIPPING WEIGHT: 5kg (11 lbs).

## NOTES

- Relative to calibration accuracy.
- With Analog Filter on, add 20ppm of reading to listed specification.
- When properly zeroed using REL function. If REL is not used, add 100nV to the range accuracy.
- Specifications include the use of ACAL function. If ACAL is not used, add 9ppm of reading/ $^\circ\text{C}$  from  $T_{\text{CAL}}$  to the listed specification.  $T_{\text{CAL}}$  is the internal temperature stored during ACAL.
- For 5PLC with 2-reading Digital Filter. Use  $\pm(4\text{ppm of reading} + 2\text{ppm of range})$  for 1PLC with 10-reading Digital Filter.
- Channel 2 must be referenced to Channel 1. Channel 2 HI must not exceed 125% (referenced to Channel 1 LO) of Channel 2 range selected.
- Noise behavior using 2188 Low Thermal Short after 2.5 hour warm-up.  $\pm 1^\circ\text{C}$ . Analog Filter off. Observation time =  $10\times$  response time or 2 minutes, whichever is less.
- For  $L_{\text{SYNC}}$  On, line frequency  $\pm 0.1\%$ . If  $L_{\text{SYNC}}$  Off, use 60dB.
- For  $1\text{k}\Omega$  unbalance in LO lead. AC CMRR is 70dB.
- For Low Q mode On, add the following to DC noise and range accuracy at stated response time: 200nV p-p @ 25s, 500nV p-p @ 4.0s,  $1.2\mu\text{V}$  p-p @ 1s, and  $5\mu\text{V}$  p-p @ 85ms.
- After 2.5 hour warm-up,  $\pm 1^\circ\text{C}$ , 5PLC, 2 minute observation time, Channel 1 10mV range only.
- For Channel 1 or Channel 2, add  $0.3^\circ\text{C}$  for external reference junction. Add  $2^\circ\text{C}$  for internal reference junction.
- Speeds are for 60Hz (50Hz) operation using factory defaults operating conditions (\*RST). Autorange Off, Display Off, Trigger Delay = 0, Analog Output off.
- Speeds include measurements and binary data transfer out the GPIB. Analog Filter On, 4 readings/s max.
- Auto Zero Off, NPLC = 0.01.
- 10mV range, 80 readings/s max.
- Sample count = 1024, Auto Zero Off.
- For  $L_{\text{SYNC}}$  On, reduce reading rate by 15%.
- For Channel 2 Low Q mode Off, reduce reading rate by 30%.
- Front Auto Zero off, Auto Zero off.
- Applies to measurements of room temperature resistances  $<10\Omega$ , Isource range  $\leq 20\mu\text{A}$ .
- Display off, delay 1ms.

1.888.KEITHLEY (U.S. only)

DISTRAME S.A. - Parc du Grand Troyes - Quartier Europe Centrale - 40, rue de Vienne - 10300 SAINTE-SAVINE  
Tél. : +33 (0)3 25 71 25 83 - Fax : +33 (0)3 25 71 28 98 - E-mail : [infos@distrame.fr](mailto:infos@distrame.fr) - Site internet : [www.distrame.fr](http://www.distrame.fr)